

Typ 510.0080.08-D Fräuserschaft

type 510.0080.08-D
toolholder

ab Bohrung \varnothing 81 mm
Nuttiefe max. 5 mm
Nutbreite 1.3 – 6 mm

min. bore \varnothing 81 mm
depth of groove max. 5 mm
width of groove 1.3 – 6 mm

ZIRKULARFRÄSEN

Nut- und Formfräsen

groove milling by
circular interpolation



Abbildung: rechtsschneidend, links verzahnt
Anzugs-Drehmoment = 3 Nm

righthand version shown, with cutting edges left
torque = 3 Nm

weitere Abmessungen auf Anfrage
Abmessungen in mm

further sizes upon request
dimensions in mm

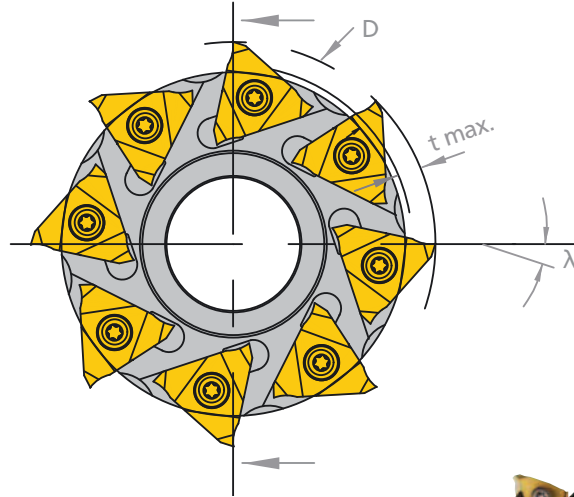
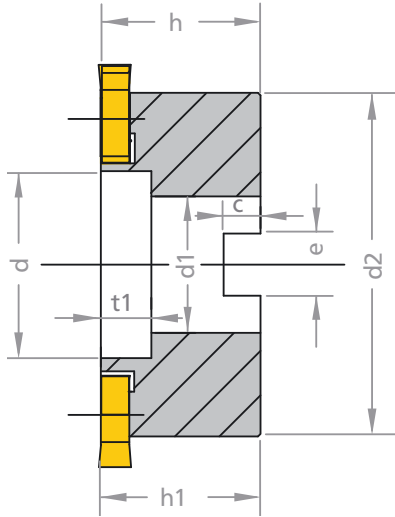
Bestellnummer part number	Schneidkreis- \varnothing D cutting edge- \varnothing D	t max.	h (ohne Fräspl.) h (without insert)	h1	Zähnezahl no. of cutting edges	d	d1	d2	passender Fräsplatten Typ (S. 64-66) type of insert (p. 64-66)
510.0080.08-D	80	5	31.6	32	8	37	27	68	514
	t1		c	e	λ°				
	10		7.3	12.3	10				

Ersatzteile
spare parts

Nutenfräser
groove milling holder
510.0080.08

Spannschraube
screw
85.818

Torx-Schlüssel
torx-screw-driver
TX-20/80