



ZIRKULARFRÄSEN

Nut- und Formfräsen

groove milling by
circular interpolation

Typ 500.34.3-D Frälerschaft

type 500.34.3-D
toolholder

ab Bohrung Ø 34 mm

min. bore Ø 34 mm

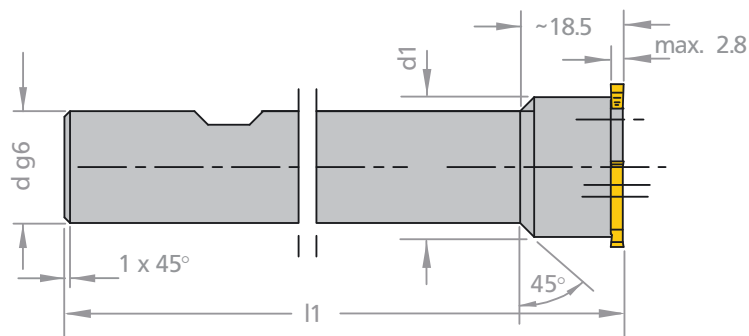
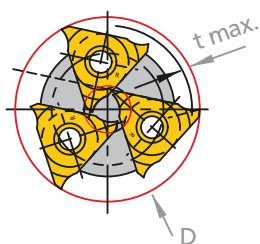

Anzugs-Drehmoment = 1.3 Nm

torque = 1.3 Nm

weitere Abmessungen auf Anfrage
Abmessungen in mm

further sizes upon request
dimensions in mm

Bestellnummer part number	Schneidkreis-Ø D cutting edge-Ø D	t max.	d1	d g6	l1	λ°	Zähnezahl no. of cutting edges	passender Fräsplatten Typ (S. 77) type of insert (p. 71)
500.34.3-D	34	2.0	25	20	100	15	3	R510 b max. = 2.8 mm

Ersatzteile
spare parts

Nutenfräser
groove milling holder
500.34.3-D

Spannschraube
screw
035.04F

Torx-Schlüssel
torx-screw-driver
TR8