

# MINIMILL

Nut- und Formzirkularfräsen

groove milling by circular interpolation

# Typ ZH28

Fräferschaft Stahl

milling shank steel

D min. 25 mm

D min. 25 mm

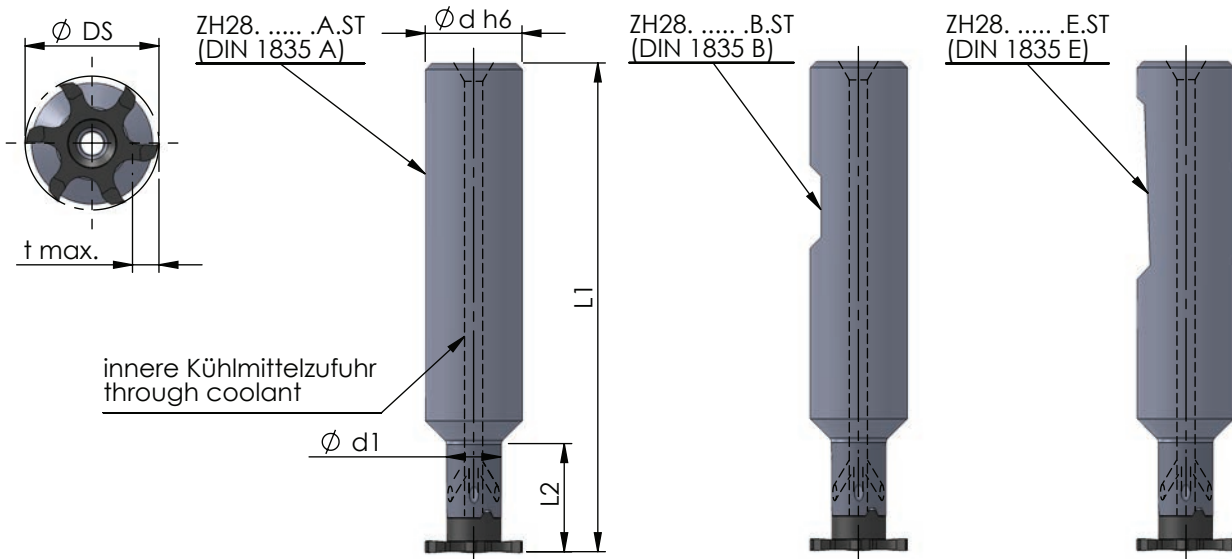

Abmessungen und Beschreibungen gelten für alle Varianten

dimensions and descriptions are valid for all versions

Abmessungen in mm

dimensions in mm

| Bestellnummer<br>part number | $\varnothing d_{h6}$ | $d_1$ | $L_1$ | $L_2$ | Typ: t max./<br>Schneidkreis- $\varnothing DS$                                             | Spannschraube<br>screw | Schraubenschlüssel<br>wrench | Anzugs-<br>drehmoment<br>torque | für Schneideinsatz<br>for insert                 |
|------------------------------|----------------------|-------|-------|-------|--------------------------------------------------------------------------------------------|------------------------|------------------------------|---------------------------------|--------------------------------------------------|
| ZH28.1314.10.A.ST            | 13                   | 14    | 70    | 10.7  | Z25: 5 / 24.8<br>Z28: 6.5 / 27.7<br>Z628: 6.5 / 27.7<br>Z32: 8.5 / 31.7<br>Z635: 10 / 34.7 | M5-MM                  | T 20F                        | 7.0 Nm                          | Z25...<br>Z28...<br>Z628...<br>Z32...<br>Z635... |
| ZH28.2014.35.A.ST / ...B.ST  | 20                   | 14    | 100   | 35.7  |                                                                                            |                        |                              |                                 |                                                  |

Bestellbeispiel:  
ZH28.2014.35.A.ST

order-example:  
ZH28.2014.35.A.ST

**MINIMILL**

Nut- und Formzirkularfräsen

groove milling by circular interpolation

**Typ ZH28**

Frälerschaft Hartmetall

D min. 25 mm

milling shank carbide

D min. 25 mm

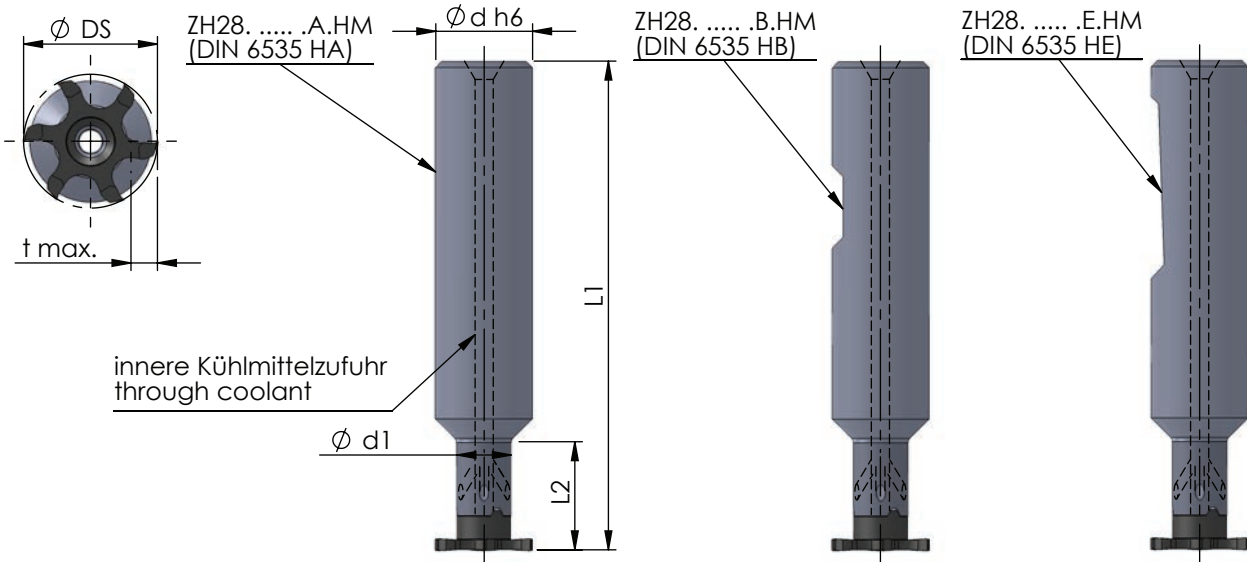

Abmessungen und Beschreibungen gelten für alle Varianten

dimensions and descriptions are valid for all versions

Abmessungen in mm

dimensions in mm

| Bestellnummer<br>part number        | Ø d h6 | Ø d (inch) | Ø d1 | L1  | L2 | Typ: t max./<br>Schneidkreis-Ø DS                                                          | Spannschraube<br>screw | Schraubenschlüssel<br>wrench | Anzugs-<br>drehmoment<br>torque | für Schneideinsatz<br>for insert                 |
|-------------------------------------|--------|------------|------|-----|----|--------------------------------------------------------------------------------------------|------------------------|------------------------------|---------------------------------|--------------------------------------------------|
| neu ZH28.U1514.42.A.HM /...B.HM     | 15.875 | 5/8"       | 14.3 | 100 | 42 | Z25: 5 / 24.8<br>Z28: 6.5 / 27.7<br>Z628: 6.5 / 27.7<br>Z32: 8.5 / 31.7<br>Z635: 10 / 34.7 | M5-MM                  | T 20F                        | 7.0 Nm                          | Z25...<br>Z28...<br>Z628...<br>Z32...<br>Z635... |
| neu ZH28.U1514.60.A.HM /...B.HM     | 15.875 | 5/8"       | 14.3 | 130 | 60 |                                                                                            |                        |                              |                                 |                                                  |
| neu ZH28.U1514.85.A.HM /...B.HM     | 15.875 | 5/8"       | 14.3 | 160 | 85 |                                                                                            |                        |                              |                                 |                                                  |
| ZH28.1614.42.A.HM /...B.HM /...E.HM | 16     |            | 14.3 | 100 | 42 |                                                                                            |                        |                              |                                 |                                                  |
| ZH28.1614.60.A.HM /...B.HM /...E.HM | 16     |            | 14.3 | 130 | 60 |                                                                                            |                        |                              |                                 |                                                  |
| ZH28.1614.85.A.HM /...B.HM /...E.HM | 16     |            | 14.3 | 160 | 85 |                                                                                            |                        |                              |                                 |                                                  |
| ZH28.2013.35.A.HM /...B.HM /...E.HM | 20     |            | 13.5 | 104 | 35 |                                                                                            |                        |                              |                                 |                                                  |
| ZH28.2014.85.A.HM /...B.HM /...E.HM | 20     |            | 14.3 | 160 | 85 |                                                                                            |                        |                              |                                 |                                                  |

Hinweis:  
Hartmetall-Frälerschäfte mit beschädigter  
Schneidplattenaufnahme können durch unseren  
Reparaturservice instand gesetzt werden.

note:  
carbide-toolholder with damaged seating can be  
repaired by Dümmel.

Bestellbeispiel:  
ZH28.2014.85.A.HM

order-example:  
ZH28.2014.85.A.HM

# MINIMILL

Nut- und Formzirkularfräsen

groove milling by circular interpolation

# Typ ZH28

Fräferschaft Schwermetall

milling shank heavy metal

D min. 28 mm

D min. 28 mm

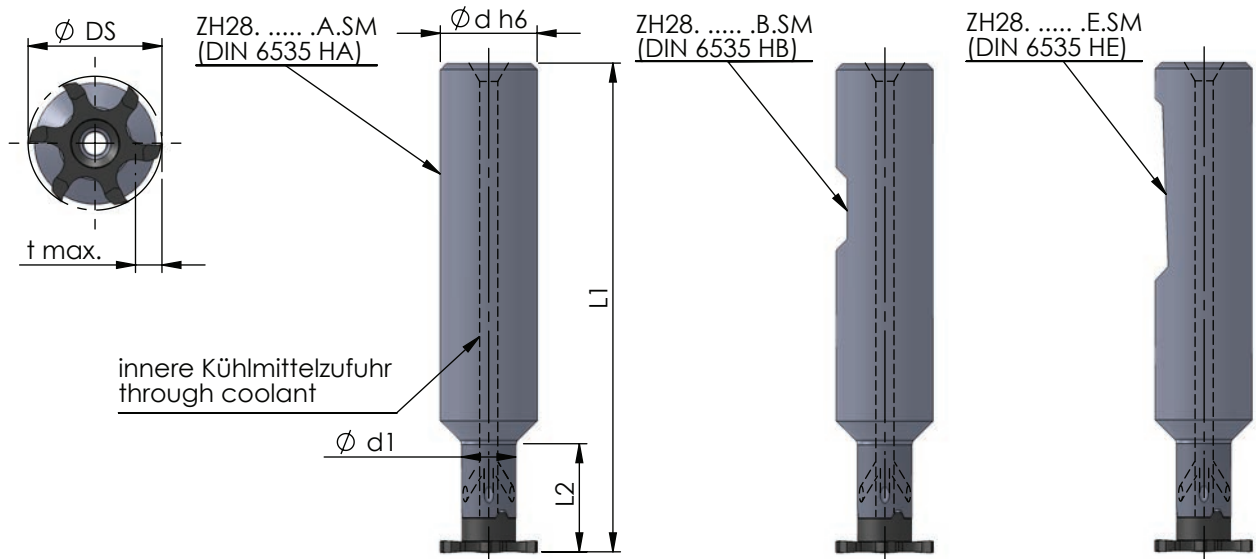

Abmessungen und Beschreibungen gelten für alle Varianten

dimensions and descriptions are valid for all versions

Abmessungen in mm

dimensions in mm

| Bestellnummer<br>part number        | $\varnothing d h6$ | d1 * | L1  | L2 | Typ: t max./ *<br>Schneidkreis- $\varnothing DS$ | Spannschraube<br>screw | Schraubenschlüssel<br>wrench | Anzugs-<br>drehmoment<br>torque | für Schneideinsatz<br>for insert |
|-------------------------------------|--------------------|------|-----|----|--------------------------------------------------|------------------------|------------------------------|---------------------------------|----------------------------------|
|                                     |                    |      |     |    |                                                  |                        |                              |                                 |                                  |
| ZH28.2020.35.A.SM /...B.SM /...E.SM | 20                 | 20   | 145 | -  |                                                  |                        |                              |                                 |                                  |
| ZH28.2015.30.A.SM /...B.SM /...E.SM | 20                 | 15   | 160 | 30 |                                                  |                        |                              |                                 |                                  |
| ZH28.2020.90.A.SM /...B.SM /...E.SM | 20                 | 20   | 200 | -  | Z28...<br>Z628...<br>Z32...<br>Z635...           |                        |                              |                                 |                                  |

\* Achtung:  
Durch die extrastabile Ausführung ist das t max. reduziert.

\* attention:  
The measure t max. is reduced by the extra-stable implementation.

Bestellbeispiel:  
ZH28.2020.90.A.SM

order-example:  
ZH28.2020.90.A.SM