

MINIMILL

Nut- und Formzirkularfräsen

groove milling by circular interpolation

Typ ZH22

Frälerschaft Stahl

milling shank steel

D min. 22 mm

D min. 22 mm

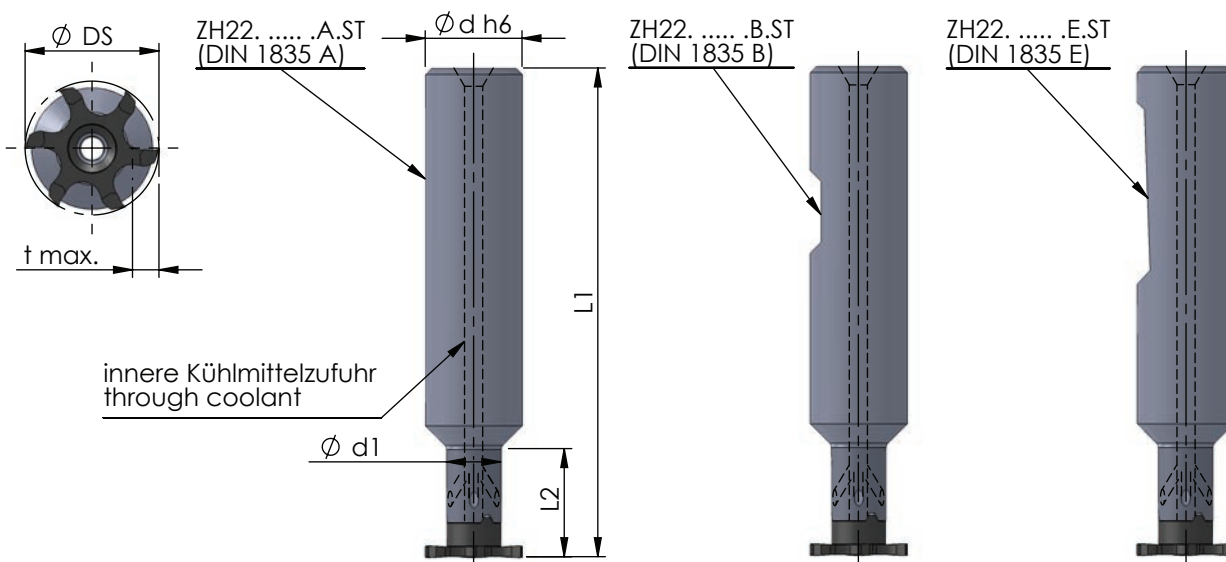

Abmessungen und Beschreibungen gelten für alle Varianten

dimensions and descriptions are valid for all versions

Abmessungen in mm

dimensions in mm

Bestellnummer part number	Ø d h6	d1	L1	L2	Typ: t max./ Schneidkreis-Ø DS	Spannschraube screw	Schraubenschlüssel wrench	Anzugs- drehmoment torque	für Schneideinsatz for insert
ZH22.1011.10.A.ST	10	11.3	60	10.7	Z22: 4.5 / 21.7 Z622: 4.5 / 21.7 Z33: 10 / 32.7 Z33: 12 / 32.7 Z637: 12 / 36.7 Z640: 13.5 / 39.7	M5-MM	T 20F	7.0 Nm	Z22...
ZH22.1311.25.A.ST	13	11.3	70	25.7					Z622...
ZH22.1612.24.A.ST /...B.ST /...E.ST	16	12	80	24					Z33...

Bestellbeispiel:
ZH22.1612.24.A.ST

order-example:
ZH22.1612.24.A.ST

MINIMILL

Nut- und Formzirkularfräsen

groove milling by circular interpolation

Typ ZH22

Fräseschaft Hartmetall

D min. 22 mm

milling shank carbide

D min. 22 mm

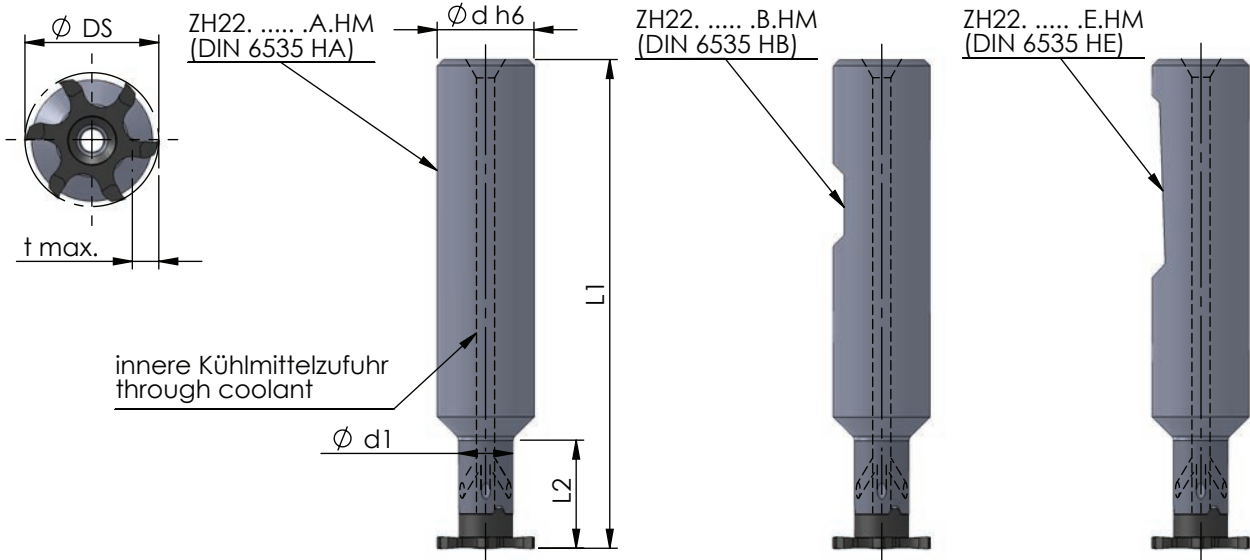

Abmessungen und Beschreibungen gelten für alle Varianten

dimensions and descriptions are valid for all versions

Abmessungen in mm

dimensions in mm

Bestellnummer part number	Ø d h6	Ø d (inch)	Ø d1	L1	L2	Typ: t max./ Schneidkreis-Ø DS	Spannschraube screw	Schraubenschlüssel wrench	Anzugs- drehmoment torque	für Schneideinsatz for insert
ZH22.1212.42.A.HM /...B.HM /...E.HM	12	-	100	42						
neu ZH22.U1212.42.A.HM /...B.HM	12.7	1/2"	-	100	42					
ZH22.1212.60.A.HM /...B.HM /...E.HM	12	-	130	60						
neu ZH22.U1212.60.A.HM /...B.HM	12.7	1/2"	-	130	60					
neu ZH22.U1511.30.A.HM /...B.HM	15.875	5/8"	11.5	90	30					
neu ZH22.U1512.42.A.HM /...B.HM	15.875	5/8"	12	100	42	Z22: 4.5 / 21.7 Z622: 4.5 / 21.7				Z22... Z622...
neu ZH22.U1512.60.A.HM /...B.HM	15.875	5/8"	12	130	60	Z33: 10 / 32.7 Z33: 12 / 32.7				Z33... Z637...
neu ZH22.U1512.85.A.HM /...B.HM	15.875	5/8"	12	160	85	Z637: 12 / 36.7 Z640: 13.5 / 39.7	M5-MM	T 20F	7.0 Nm	Z640...
ZH22.1611.30.A.HM /...B.HM /...E.HM	16	-	11.5	90	30					
ZH22.1612.42.A.HM /...B.HM /...E.HM	16	-	12	100	42					
ZH22.1612.60.A.HM /...B.HM /...E.HM	16	-	12	130	60					
ZH22.1612.85.A.HM /...B.HM /...E.HM	16	-	12	160	85					
ZH22.2016.45.A.HM /...B.HM /...E.HM	20	-	16	110	45	t max. reduziert				
ZH22.2016.65.A.HM /...B.HM /...E.HM	20	-	16	130	65	t max. reduced				

Hinweis:
Hartmetall-Fräseschäfte mit beschädigter
Schneidplattenaufnahme können durch unseren
Reparaturservice instand gesetzt werden.

note:
carbide-toolholder with damaged seating can be
repaired by Dümmel.

Bestellbeispiel:
ZH22.2016.65.A.HM

order-example:
ZH22.2016.65.A.HM