



# MINIMILL

Nut- und Formzirkularfräsen

groove milling by circular interpolation

# Typ Z625.X

Nutfräsen allgemein

general use

Bohrungs-Ø ab 25 mm

bore Ø from 25 mm

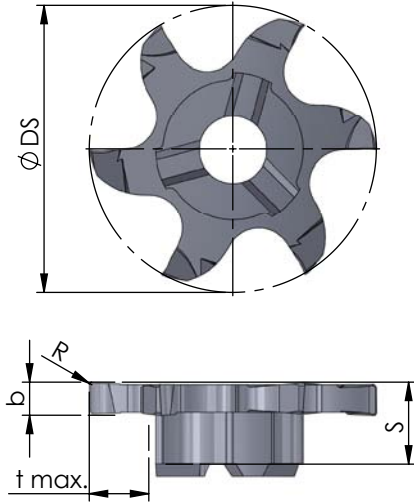

Schneide / tooth 2-4-6

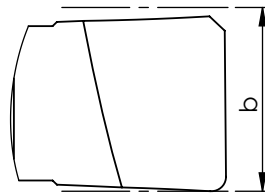

Schneide / tooth 1-3-5

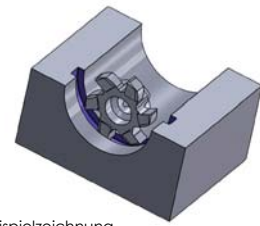
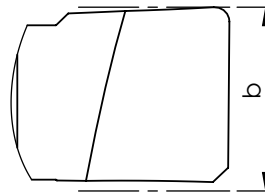

Beispielzeichnung  
exemplary application

Abmessungen in mm

dimensions in mm

	Bestellnummer part number	D min.	S	R	Ø DS	b +0.02	t max.	Zähnezahl number of teeth	für Fräseschaft for toolholder type		
									K10F	AL41F	P18C
neu	Z625.X250.02	25	6.4	0.2	24.8	2.5	5.0	6	●		
neu	Z625.X300.02	25	6.4	0.2	24.8	3.0	5.0	6	●		
neu	Z625.X400.02	25	6.4	0.2	24.8	4.0	5.0	6	●		
neu	Z625.X500.02	25	6.4	0.2	24.8	5.0	5.0	6	●		
neu	Z625.X600.02	25	6.4	0.2	24.8	6.0	5.0	6	●		ZH28

Weitere HM Sorten können Sie in der Sortenübersicht im Kapitel "Technische Hinweise" und der Preisliste finden.

Bestellbeispiel:  
für Sorte AL41F:  
Z625.X200.01/AL41F

More carbide grades you can find in the grades summary in the chapter "technical instructions" and in the price list.

order-example:  
grade AL41F:  
Z625.X200.01/AL41F