

# MINIMILL

Nut- und Formzirkularfräsen

groove milling by circular interpolation

# Typ Z622

für Whitworth-Gewinde innen Vollprofil

for Whitworth threading internal full profile

Bohrungs-Ø ab 22 mm

bore Ø from 22 mm

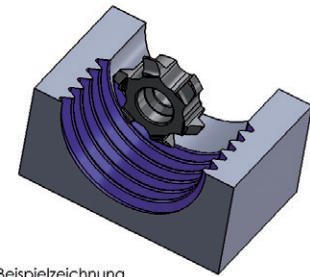
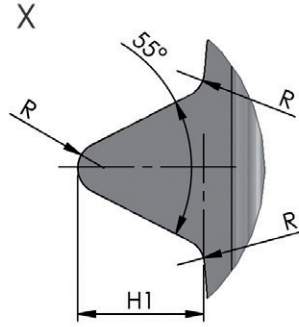
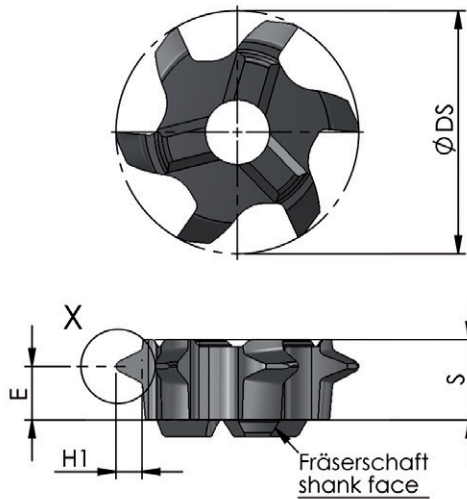

Beispielzeichnung  
exemplary application

Abmessungen in mm

dimensions in mm

	Bestellnummer part number	min. Gewindegröße min. thread size	Steigung pitch	Gang/Zoll stars/inch	S	E	Ø DS	H1	R	Zähnezahl number of teeth	Material			für Fräaserschaft for toolholder type
											K10F	AL41F	P18C	
neu	Z622.5506.02	BSW1½	4.233	6	6.05	3.75	21.7	2.71	0.58	6	●	●	●	ZH22
neu	Z622.5508.02	-	3.175	8	6.35	4.25	21.7	2.03	0.43	6	●	●	●	
neu	Z622.5511.02	G1"	2.31	11	6.35	4.75	21.7	1.48	0.31	6	●	●	●	

weitere HM Sorten siehe Hauptkatalog Seite 370

more carbide grades main catalogue page 370

Bestellbeispiel:  
für Sorte AL41F:  
Z622.5506.02/AL41F

order-example:  
grade AL41F:  
Z622.5506.02/AL41F