

MINIMILL

Nut- und Formzirkularfräsen

groove milling by circular interpolation

Typ Z622 / Z622.X

Nutfräsen allgemein

for groove milling general use

D min. 22 mm
t max. = 4.5

D min. 22 mm
t max. = 4.5

Z622 geradverzahnt / spur-toothed

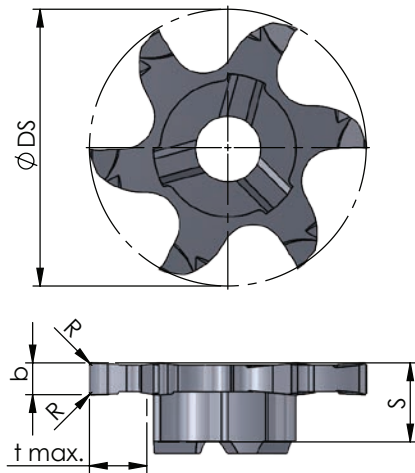

Z622.X kreuzverzahnt / staggered-toothed

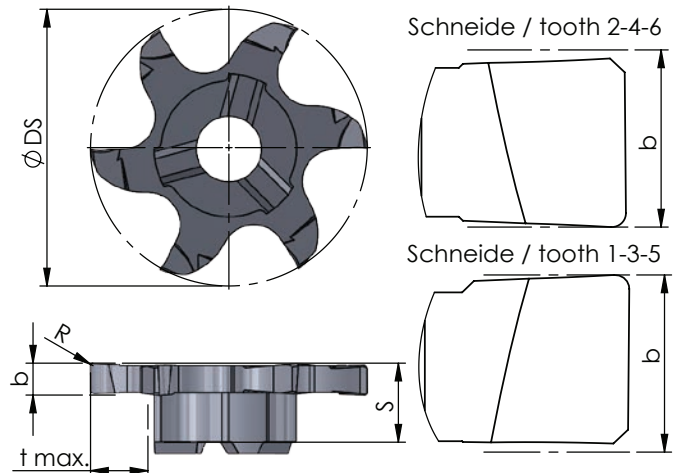

Abmessungen in mm

dimensions in mm



Bestellnummer part number	D min.	S	R	Ø DS	b +0.02	t max.	Zähnezahl number of teeth				für Fräterschaft for milling shank
								K10F	AL41F	P18C	
Z622.0100.01	22	5.8	0.1	21.7	1.0	4.5	6	●			ZH22...
Z622.0150.01	22	6.2	0.1	21.7	1.5	4.5	6	●			
Z622.0200.02	22	6.2	0.2	21.7	2.0	4.5	6	●			
Z622.X200.02	22	6.2	0.2	21.7	2.0	4.5	6	●			
Z622.0250.02	22	6.2	0.2	21.7	2.5	4.5	6	●			
Z622.X250.02	22	6.2	0.2	21.7	2.5	4.5	6	●			
Z622.0300.02	22	6.2	0.2	21.7	3.0	4.5	6	●			
Z622.X300.02	22	6.2	0.2	21.7	3.0	4.5	6	●			
Z622.0400.02	22	6.2	0.2	21.7	4.0	4.5	6	●			
Z622.X400.02	22	6.2	0.2	21.7	4.0	4.5	6	●			

Weitere HM Sorten können Sie in der Sortenübersicht im Kapitel "Technische Hinweise" und der Preisliste finden.

Bestellbeispiel:
für Sorte AL41F:
Z622.0150.01/AL41F

More carbide grades you can find in the grades summary in the chapter "technical instructions" and in the price list.

order-example:
grade AL41F:
Z622.0150.01/AL41F