

MINIMILL

Nut- und Formzirkularfräsen

groove milling by circular interpolation

Typ Z22

Vollradius

D min. 22 mm
t max. = 4.5

full radius

D min. 22 mm
t max. = 4.5

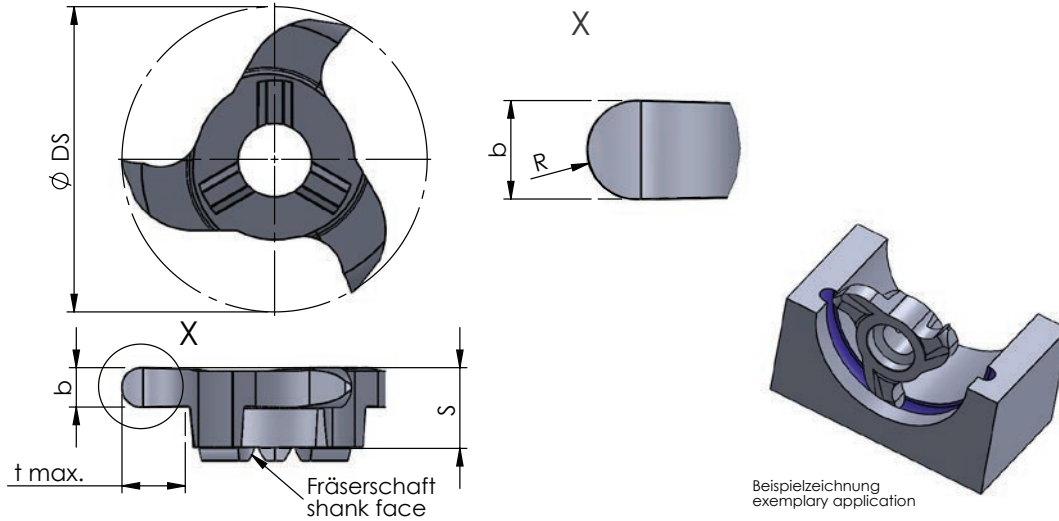

Abmessungen in mm

dimensions in mm

| Bestellnummer part number | D min. | S | R | Ø DS | b +0.03 | b (inch) | t max. | Zähnezahl number of teeth | | | | für Fräterschaft for milling shank |
|------------------------------|--------|------|------|------|---------|----------|--------|------------------------------|------|-------|------|---------------------------------------|
| | | | | | | | | | K10F | AL41F | P18C | |
| Z22.0005.10 | 22 | 5.75 | 0.5 | 21.7 | 1.0 | | 4.5 | 3 | | ● | | ZH22... |
| Z22.0008.16 | 22 | 5.75 | 0.8 | 21.7 | 1.6 | | 4.5 | 3 | | ● | | |
| Z22.0010.20 | 22 | 5.75 | 1.0 | 21.7 | 2.0 | | 4.5 | 3 | ● | ● | | |
| Z22.0012.24 | 22 | 5.75 | 1.2 | 21.7 | 2.4 | | 4.5 | 3 | | ● | | |
| Z22.0014.28 | 22 | 5.75 | 1.4 | 21.7 | 2.8 | | 4.5 | 3 | | ● | | |
| Z22.0015.30 | 22 | 5.75 | 1.5 | 21.7 | 3.0 | | 4.5 | 3 | | ● | | |
| Z22.U015.31 | 22 | 5.75 | 1.57 | 21.7 | 3.17 | 0.125" | 4.5 | 3 | | ● | | |
| Z22.0020.40 | 22 | 5.75 | 2.0 | 21.7 | 4.0 | | 4.5 | 3 | | ● | | |
| Z22.0022.44 | 22 | 5.75 | 2.2 | 21.7 | 4.4 | | 4.5 | 3 | | ● | | |
| Z22.0025.50 | 22 | 5.75 | 2.5 | 21.7 | 5.0 | | 4.5 | 3 | | ● | | |

Weitere HM Sorten können Sie in der Sortenübersicht im Kapitel "Technische Hinweise" und der Preisliste finden.

Bestellbeispiel:
für Sorte AL41F:
Z22.0025.50/AL41F

More carbide grades you can find in the grades summary in the chapter "technical instructions" and in the price list.

order-example:
grade AL41F:
Z22.0025.50/AL41F