

# Z22

für metrische ISO-Gewinde

innen Teilprofil  
ab Bohrung Ø 22 mm

for metric standard threading

internal partial profile  
min. bore Ø 22 mm

# MINIMILL

Nut- und Formzirkularfräsen

groove milling by circular interpolation

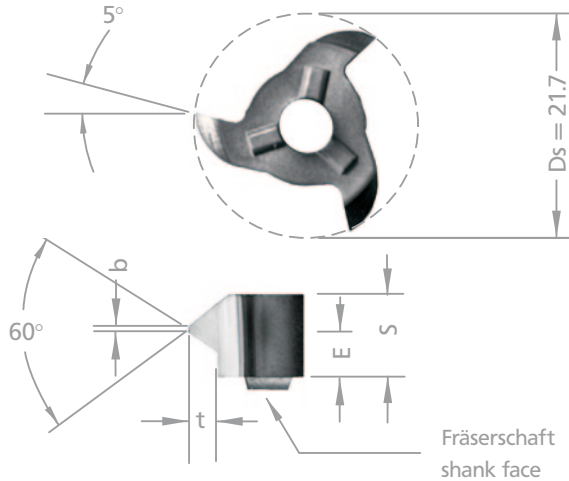

Abmessungen in mm

dimensions in mm

Profil ISO standard insert standard thread

Bestellnummer part number	min. Gewindegröße min. thread size	Steigung P pitch P	Z22			Zähnezahl number of teeth	für Frälerschaft (S. 271) for toolholder type (p. 271)	Standard HM Sorte standard carbide grade
			S	F	t max.			
Z22.0720.01	M27	1.0 - 2.0	5.85	4.6	1.19	3	ZH22	AL41F (=TiAlN)
Z22.0815.01	M27	1.5 - 2.75	5.85	4.8	1.62	3	ZH22	
Z22.1020.01	M27	2.0 - 3.75	5.85	4.6	2.22	3	ZH22	
Z22.1630.01	M30	2.5 - 5.0	5.85	4.0	2.98	3	ZH22	
Z22.2140.01	M30	3.5 - 6.0	5.85	3.9	3.52	3	ZH22	
Z22.2445.01	M30	3.5 - 6.5	5.85	3.7	3.84	3	ZH22	
Z22.2545.01	M27	2.0 - 4.5	5.85	3.7	2.71	3	ZH22	

HM Sorten siehe S. 370  
«Sortenübersicht» und Preisliste

Bestellbeispiel:  
für Sorte AL41F:  
Z22.2140.01/AL41F

carbide grades p. 370 see «grades  
summary» and according price list

order-example:  
grade AL41F:  
Z22.2140.01/AL41F