

ULTRAMINI

Bohrungsbearbeitung
ab $\varnothing 0.2$ mm

grooving, boring and profiling
starting at $\varnothing 0.2$ mm

Typ Gewindedrehen

NPT Teilprofil

type threading,
NPT partial profile

Bohrungs- \varnothing ab 6.0 mm

bore \varnothing from 6.0 mm

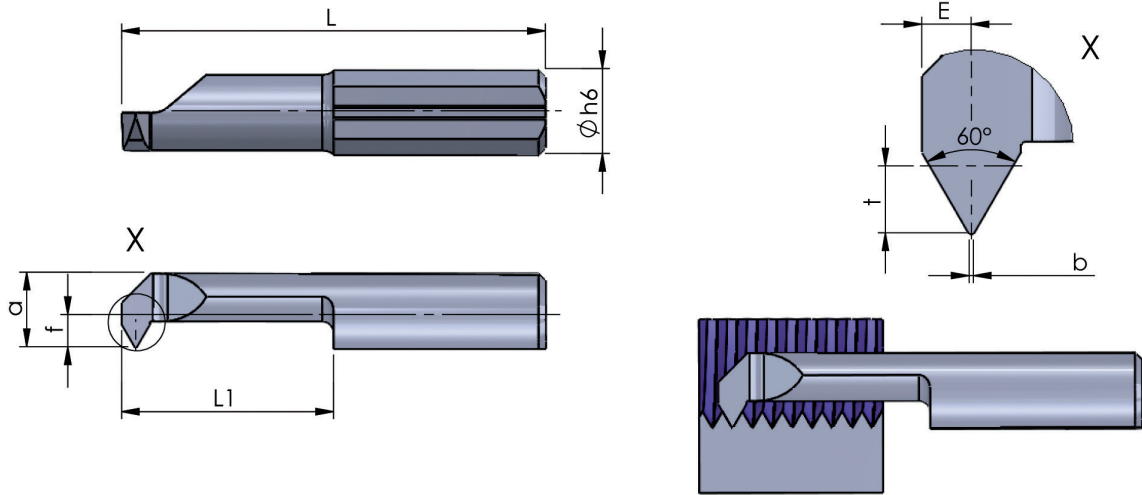

Ansicht X: vergrößert
Abbildung: rechtsschneidend

Ausführung rechts (R) oder
links (L) angeben

Abmessungen in mm

view X: enlarged
righthand version shown

state right (R) or left (L) version

dimensions in mm



	Bestellnummer part number	P Steigung P pitch	t	Gg Zoll Gg inch	b	E	f	a	L	L1	\varnothing h6	Klemmhalter Typ toolholder type			
												K10F	CN45F	AL41F	
neu	R/L 006.NP18-15	1.411	1.35	18	0.09	1	2.3	5.3	30	15	6				
neu	R/L 006.NP18-22	1.411	1.35	18	0.09	1	2.3	5.3	37	22	6				
neu	R/L 006.NP27-15	0.940	1	27	0.06	0.8	2.3	5.3	30	15	6				676.xxx
neu	R/L 006.NP27-22	0.940	1	27	0.06	0.8	2.3	5.3	37	22	6				660 xxx.6

weitere HM Sorten siehe Hauptkatalog Seite 92

Bestellbeispiel:
für rechte Ausführung und Sorte
R006.NP18-15/AL41-F

more carbide grades main catalogue page 92

order-example:
righthand version and grade
R006.NP18-15/AL41-F