



ULTRAMINI

Bohrungsbearbeitung
ab \varnothing 0.2 mm

grooving, boring and profiling
starting at \varnothing 0.2 mm

Typ / type 047

Ausdrehen Kopieren
mit Geometrie 47°

profiling and copying
with 47° geometry

ab Bohrung \varnothing 4.0 mm

bore \varnothing from 4.0 mm



Abbildung: rechtsschneidend

Ausführung rechts (R)
oder links (L) angeben
Abmessungen in mm

righthand version shown

state right (R) or left (L) version

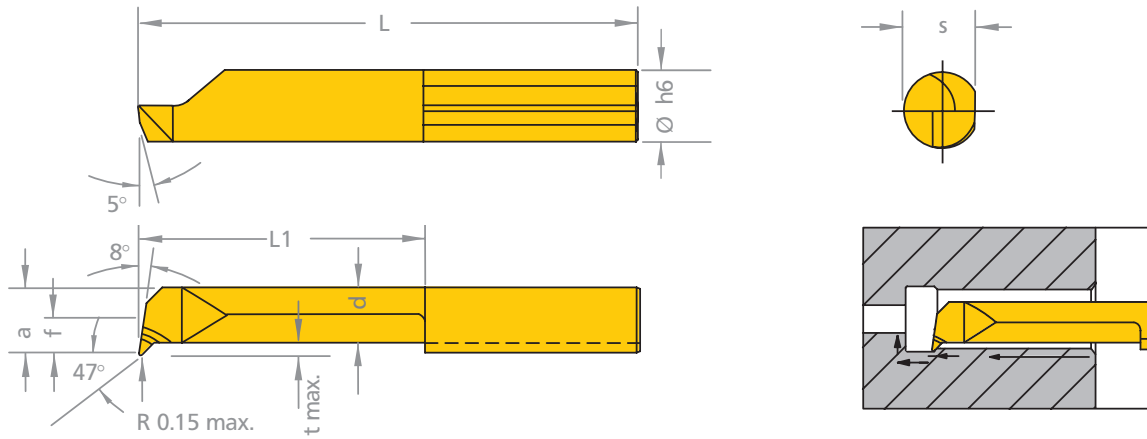
dimensions in mm



Version T mit erweitertem t max.

version T with extended t max.

Bestellnummer part number										passende Werkzeughalter suitable toolholder	
	s	f	d	a	L	L1	t max.	D min.	\varnothing h6		
R/L 047.T2-10	3.5	–	1.2	1.7	24	10	0.4	2.0	4.0	645.xxx	xxx.4
R/L 047.T3-15	3.5	0.6	1.9	2.6	29	15	0.6	2.8	4.0		
R/L 047.T4-10	3.5	1.5	2.8	3.5	24	10	0.6	4.0	4.0		
R/L 047.4-20	3.5	1.5	3.0	3.5	34	20	0.3	4.0	4.0		
R/L 047.T4-20	3.5	1.5	2.8	3.5	34	20	0.6	4.0	4.0		
R/L 047.T5-15	4.4	1.9	3.5	4.4	30	15	0.8	5.0	5.0	xxx.5	
R/L 047.5-25	4.4	1.9	3.8	4.4	40	25	0.5	5.0	5.0		
R/L 047.T5-25	4.4	1.9	3.5	4.4	40	25	0.8	5.0	5.0		
R/L 047.T6-22	5.3	2.3	3.4	5.3	37	22	1.8	6.0	6.0	676.xxx	660 / xxx.6
R/L 047.6-30	5.3	2.3	4.5	5.3	45	30	0.5	6.0	6.0		
R/L 047.T6-30	5.3	2.3	3.4	5.3	45	30	1.8	6.0	6.0		

Weitere HM Sorten können Sie in der Sortenübersicht im Kapitel »Technische Hinweise« und der Preisliste finden.

Bestellbeispiel:
für rechte Ausführung und Sorte
CN45F: R047.T2-10/CN45F

More carbide grades you can find in the grades summary in the chapter »technical instructions« and in the price list.

order-example: righthand version
and grade
CN45F: R047.T2-10/CN45F