



ULTRAMINI

Bohrungsbearbeitung

grooving, boring and profiling

Typ 050 B Ausdrehen Kopieren mit innerer Kühlbohrung

type 050 B
boring/ profiling copying
with internal cooling channel

Bohrungs-Ø ab 6.0 mm
Auskragung (L1) bis 7x D

bore Ø from 6.0 mm
overhang length (L1)
up to 7x D



Abbildung: rechtsschneidend

righthand version shown

Ausführung rechts (R) oder links (L) angeben
Abmessungen in mm

state right (R) or left (L) version
dimensions in mm

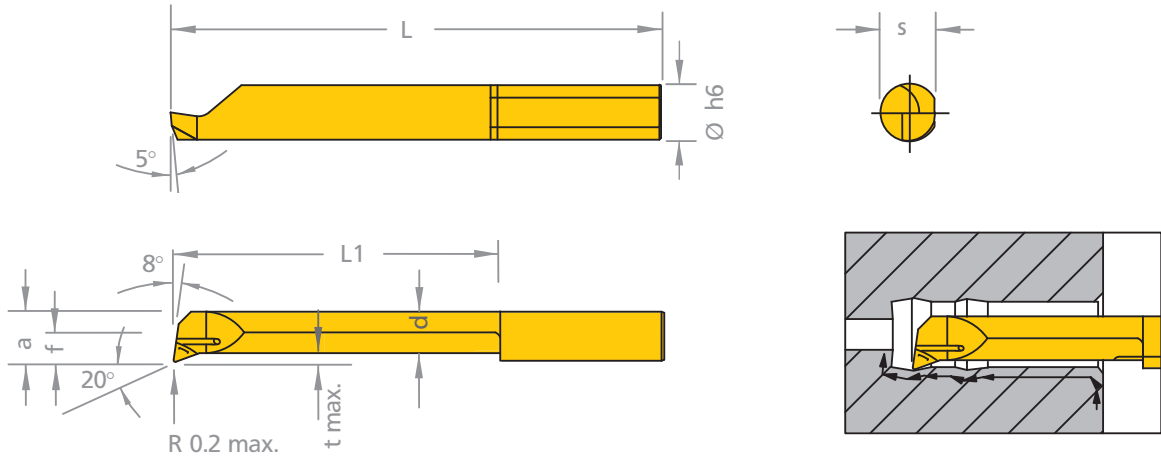

Bestellnummer
part number

s f d a L L1 t max. D min. Ø h6

passende
Klemmhalter
Typen (S. 14+15)
suitable toolholder
types (p. 14+14)

R/L 050.6-35B	5.3	2.3	4.5	5.3	50	35	0.5	6.0	6.0
R/L 050.6-42B	5.3	2.3	4.5	5.3	57	42	0.5	6.0	6.0
R/L 050.7-35B	6.3	2.8	5.5	6.3	50	35	0.6	6.8	7.0
R/L 050.7-40B	6.3	2.8	5.5	6.3	55	40	0.6	6.8	7.0
R/L 050.7-45B	6.3	2.8	5.5	6.3	60	45	0.6	6.8	7.0
R/L 050.7-50B	6.3	2.8	5.5	6.3	65	50	0.6	6.8	7.0

K 676
676

687

Was bedeutet rote Linie in der Korrektur?

HM Sorten siehe S. 64
«Sortenübersicht» und Preisliste

carbide grades p. 64 see «grades
summary» and according price list

Bestellbeispiel: für rechte Ausführung
und Sorte AL41F: R050.6-35B/AL41F

order-example: righthand version
and grade AL41F: R050.6-35B/AL41F