

ULTRAMINI

Bohrungsbearbeitung
ab $\varnothing 0.2$ mm

grooving, boring and profiling
starting at $\varnothing 0.2$ mm

Typ 10M

Stechdrehen
mit Eckenradius und
innerer Kühlmittelzufuhr

grooving
with corner radius and
with through coolant

D min. 10.5 mm
Stechtiefe t max. 4.0 mm

D min. 10.5 mm
depth of groove t max. 4.0 mm

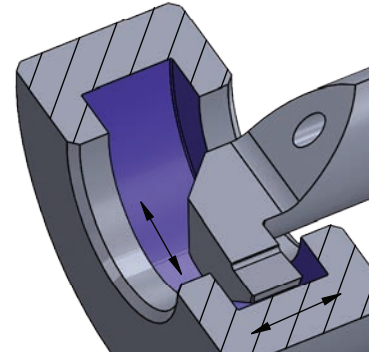
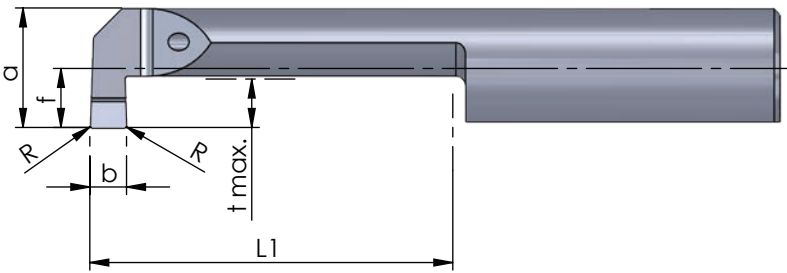
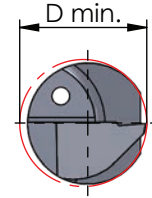
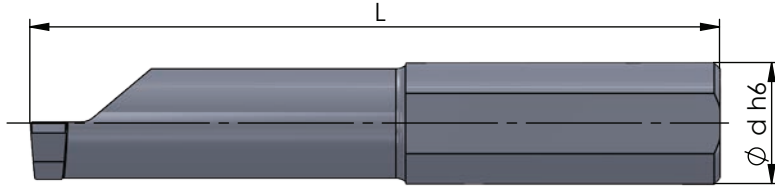

Rechts (R): wie gezeichnet
Links (L): spiegelbildlich

righthand (R): as shown
lefthand version (L): mirror image

Abmessungen in mm

dimensions in mm

	Bestellnummer part number	b +0.05	R	f	a	L	L1	t max.	D min.	Ø d h6	Klemmhalter Typ toolholder type				
											K10F	CN45F	AL41F	P07C	
neu	R/L 10M0100-30	1.0	0.1	4.9	9.9	57	30	4.0	10.5	10		●			681...
neu	R/L 10M0100-50	1.0	0.1	4.9	9.9	77	50	4.0	10.5	10		●			
neu	R/L 10M0200-30	2.0	0.1	4.9	9.9	57	30	4.0	10.5	10		●			
neu	R/L 10M0200-50	2.0	0.1	4.9	9.9	77	50	4.0	10.5	10		●			
neu	R/L 10M0300-30	3.0	0.1	4.9	9.9	57	30	4.0	10.5	10		●			
neu	R/L 10M0300-50	3.0	0.1	4.9	9.9	77	50	4.0	10.5	10		●			

Weitere HM Sorten können Sie in der Sortenübersicht im Kapitel "Technische Hinweise" und der Preisliste finden.

More carbide grades you can find in the grades summary in the chapter "technical instructions" and in the price list.

Bestellbeispiel:
für rechte Ausführung und Sorte
R10M0100-30/AL41F

order-example:
righthand version and grade
R10M0100-30/AL41F